

INSTRUCTION MANUAL



H-KING F-18 50MM EDF 4S WITH ORX FLIGHT STABILIZER

Please read this manual carefully before operating this plane.

PNF VERSION

H-KING

WARNING

Read this instruction manual fully so as to become completely familiar with the features of the product before operating. Failure to operate this product correctly could result in damage to the product, personal property and cause serious injury. This is a sophisticated hobby product and is NOT a toy. It must always be operated with caution, common sense and some basic mechanical ability. This manual provides instructions on the assembly, safe operation and maintenance of this hobby product. It is highly recommended that you read and follow fully the instructions and warnings stated in this manual including safety, assembly, set-up and flying guidelines in order to operate this product correctly and avoid damage or serious injury.

SAFETY PRECAUTIONS

As the user of this product you and you alone are responsible for operating it in a manner that does not endanger yourself and others around you or result in damage to the product or property of others. This product is operated via a radio controlled system that in some cases can be subject to interference from sources outside of your control. Interference may result in a momentary loss of control so it is always recommended that this product be used in a suitable open outdoors space.

- This is a radio controlled flying model and as such must always be flown with caution, this is NOT a toy.
- The H-King brief was to design a model for low hours to intermediate pilots.
- Always exercise great caution when using the recommended battery to power this product. For full safety notes and operating procedures please read the information provided by your battery supplier.
- Take great care when connecting/disconnecting the battery. Once again see your battery suppliers information for the full safety procedures.
- Never power up the model in a confined space and always keep the fan air intake clear of obstructions, clothing and anything that can be drawn into the fan unit.
- This product is not a toy, children must be accompanied by an adult at all times when operating this product.
- Only fly this model in an open area away from crowds, people, buildings, trees, power lines, roads, airports and other obstructions.
- Always put safety first when operating this model and consider the warnings stated above.
- The supplier/manufacturer accepts no responsibility for damage or injury caused through the use of this product. A reminder that it is not suitable for children under the age of 14. THIS IS NOT A TOY.



SPECIFICATION

- Length: 800mm
- Wing span: 588mm
- Weight w/battery: 4S Li-Po 1300 mAh (500g +/-10g)
- Power: 50mm EDF 4S high power brushless motor.
- Radio: Radio: 6ch and up with electronic mixing capability computer radio (Recommended)
- Battery: 1000-1300 mAh 4S Li-Po 30-60C (Recommended)
- ESC: 30A with BEC
- Servo: 4 x 9g

CONTENTS



1. Fuselage
2. Canopy
3. Main wing set
4. Vertical fin
5. Horizontal stabilizer
6. Nose cone
7. Carbon fiber wing joiner
8. Pushrods
9. Double sided tape

ASSEMBLY INSTRUCTIONS

MAIN WING

1. Pass the supplied carbon fiber wing joiner through the fuselage

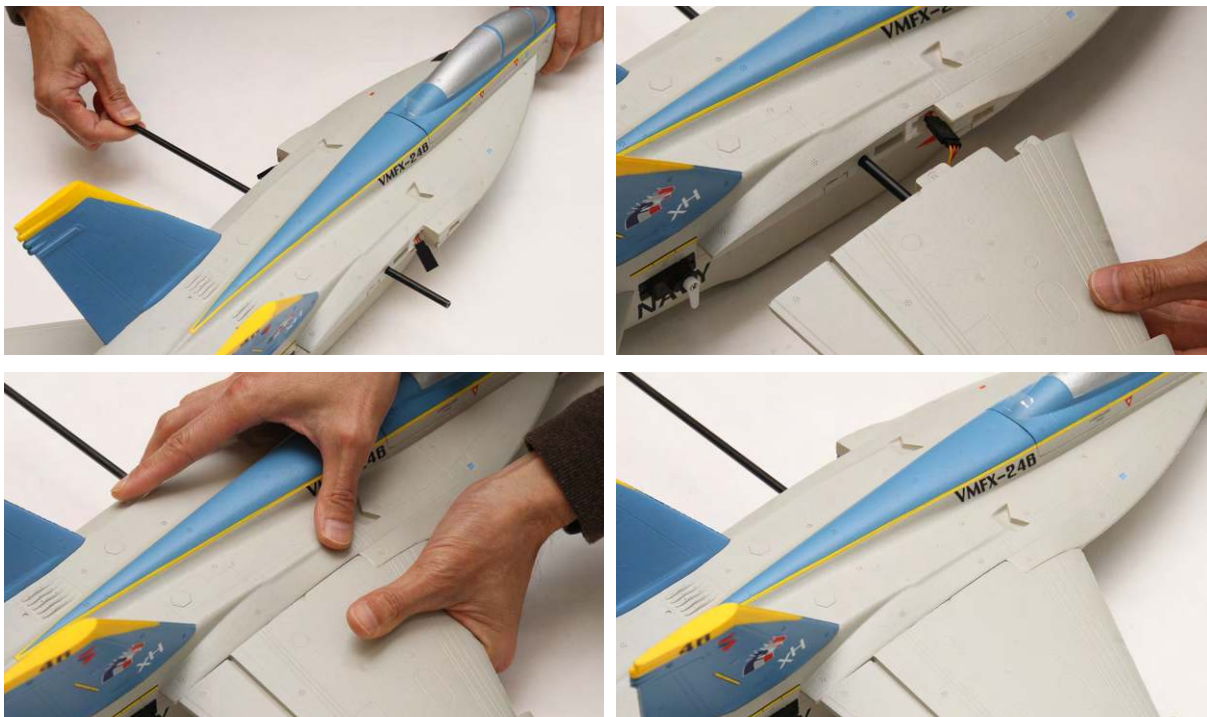

2. Install the right wing onto the fuselage and connect the wing servo lead. Then gently push the wing against the fuselage until it hits the magnet on the wing saddle. The servo lead should also be tucked nicely inside the groove in between the wing and the fuselage. The built-in magnet wing locking system on the wing saddle will hold the wing securely.

3. Repeat Step #2 for the left wing.

HORIZONTAL STABILIZER

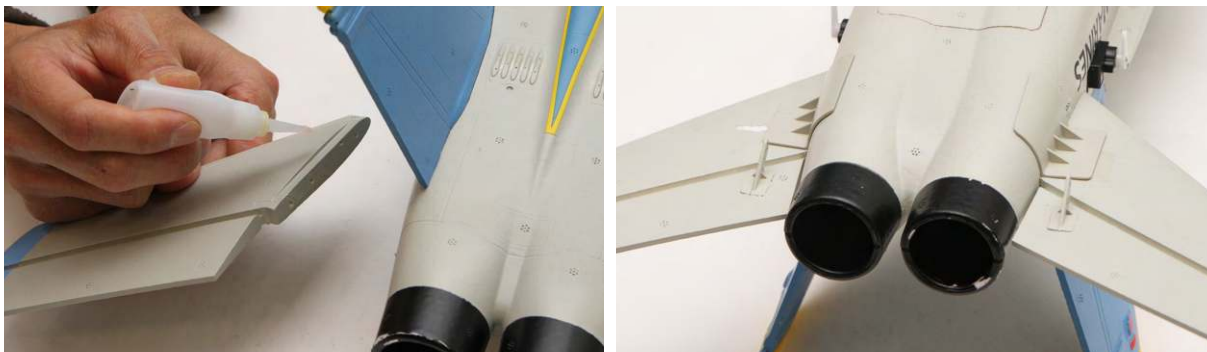

1. Get the Left/Right stabilizer parts ready. Apply foam safe glue to the root of the stabilizer and install the left hand side stab onto the fuselage tail as shown.
2. Repeat the above steps for the right-hand side horizontal stabilizer.
3. View the model from the front, ensure the left and right horizontal stabilizer are installed correctly, check this frequently as the glue dries.

VERTICAL FIN

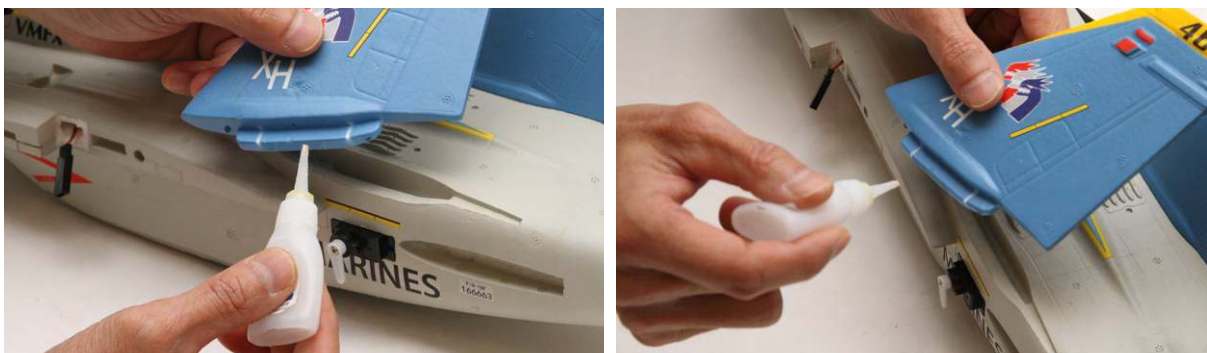

Apply a thin layer of foam safe glue to one of the vertical fins and install it onto the fuselage as shown. Repeat this process for the other fin, check the alignment frequently as the glue dries.

NOSE CONE



Use a foam safe glue to attach the nose cone.

YOUR F-18 BUILD IS COMPLETE



C OF G POSITION

The C of G is 48-53 mm from the wings leading edge. For first flights we recommend you use the forward measurement. Once you get used to the model you can then move it back, do not though exceed the most rearward measurement.

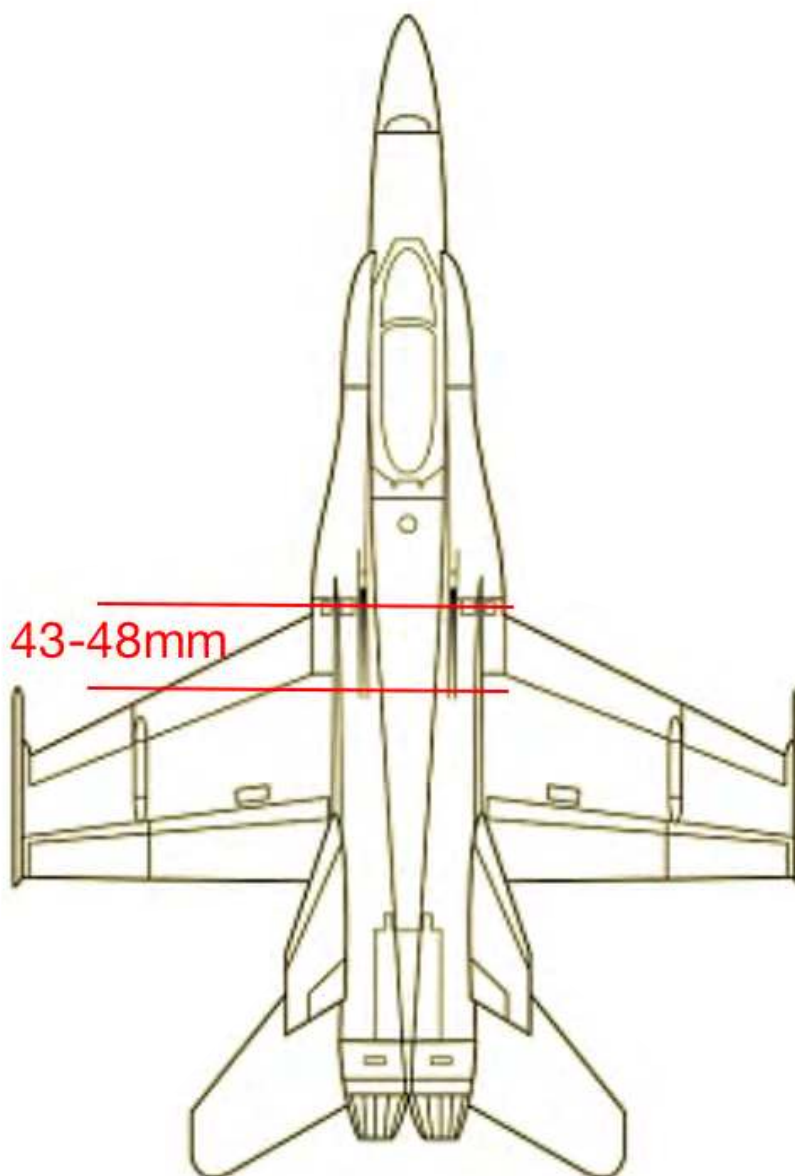

F-18 ORX FLIGHT STABILISATION SYSTEM

FEATURES

- Integrated with a 32bit MCU and a 6 axis digital gyro for ultra fast flight control response.
- The ORX stabilisation device is tuned specifically to a particular model for the best flying performance.
- Supports PWM, PPM and SBUS. Auto-detect.
- Supports 3 different flight modes (Beginner, Intermediate and Expert)

CHANNEL INPUT

Flight mode (a 3-way toggle switch should be assigned for flight mode selection)

PWM input: Ch 1. Aileron, Ch 2. Elevator, Ch 3 Throttle, and Ch 5 Flight mode (a 3-way toggle switch should be assigned for flight mode selection)

PPM input: Plug the flight mode/SBUS/PPM channel input plug into your receiver which supports PPM out. Here is the Ch assignment and shown as follow. Ch 1. Aileron, Ch 2. Elevator, and Ch 3 Throttle. Ch 5 (a 3-way toggle switch should be assigned for flight mode selection)

SBUS input: Plug the Flight mode/SBUS/PPM channel input plug into a receiver which supports SBUS. CH 5 (a 3-way toggle switch should be assigned for flight mode selection)

PUSHROD LINKAGES SETUP

Connect the ORX via one of the PWM/PPM/SBUS inputs of your chosen receivers. Connect a 4S Li-Po battery pack and switch on your TX to prepare to set the throws of the control surfaces. Ensure the servo horns on all servo output shafts are perpendicular to servo cases, and all control surfaces are perfectly level. Reset all electronic trims on your TX to the centre position and remove any Dual Rates/End points settings, leave them at 100% and expo at 0%. There are two sets of pushrods which come with the kit. The shorter ones are used for ailerons and the longer ones are used for elevators. Install the supplied longer pushrod to the right-hand side elevator servo horn and use the **third** hole from the top as shown. Then repeat the above steps for the elevator servo on the left-hand side. If you are happy with the above setup, you may start to set up aileron control surfaces. Install the supplied shorter pushrod to the right-hand side aileron servo horn and use the **fourth** hole from the top as shown. Then repeat the above steps to install the pushrod linkage on the left-hand side.

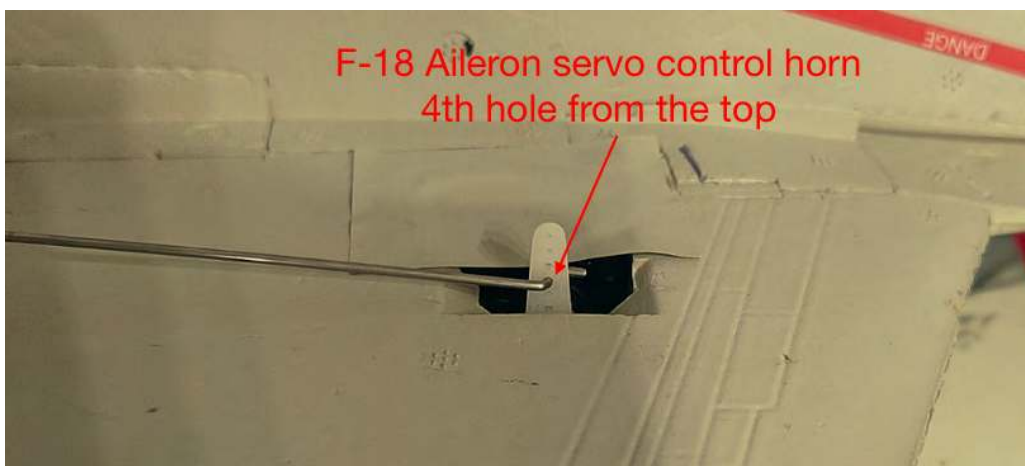
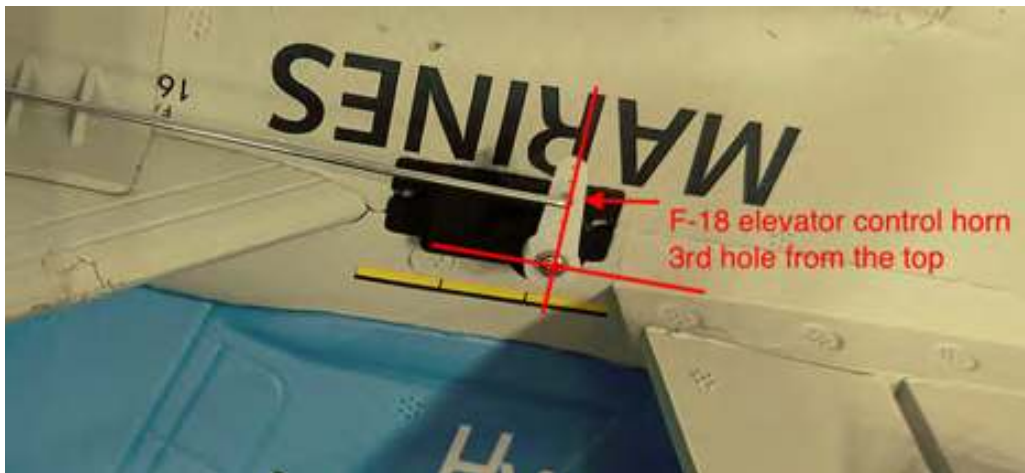

TX AND ORX STABILISATION DEVICE SETUP

Note: If you wish to set up Expo/Dual rates on the elevator and aileron channels to meet your flying style, you must set them only under the Intermediate and Expert flight mode.

SWITCH ON THE TX

Place your F-18 50mm EDF on level ground. Plug in your battery flight pack and let it sit still, during this time the plane is in auto self-calibration mode. The LED light on the stabilization device will keep flashing rapidly for 3-6 secs, then the light will remain solid. In the mean time the aileron, and elevator control surfaces will move up/ down, and left/right 3 times to indicate the self-calibration is successful.

When the self calibration has been carried out the stabilization system is still not in ready mode. Now check to see if all the control surfaces are in a neutral position. If not, please adjust the push-rod clevises to ensure all the control surfaces are neutral before flight, then cycle the battery power to store this setup.

After all these setup procedure have been completed, plug in the battery once again and wait until all the control surfaces move up/down and left/right 3 times to confirm the self- calibration before flight.

At this point the gyro is not in ready mode until you give the throttle a short blip 10-15% in order to switch on the stabilization system. Check that the gyro responds accordingly to the plane when being tilted up/down in pitch, left/right in roll.

LED INDICATION STATUS

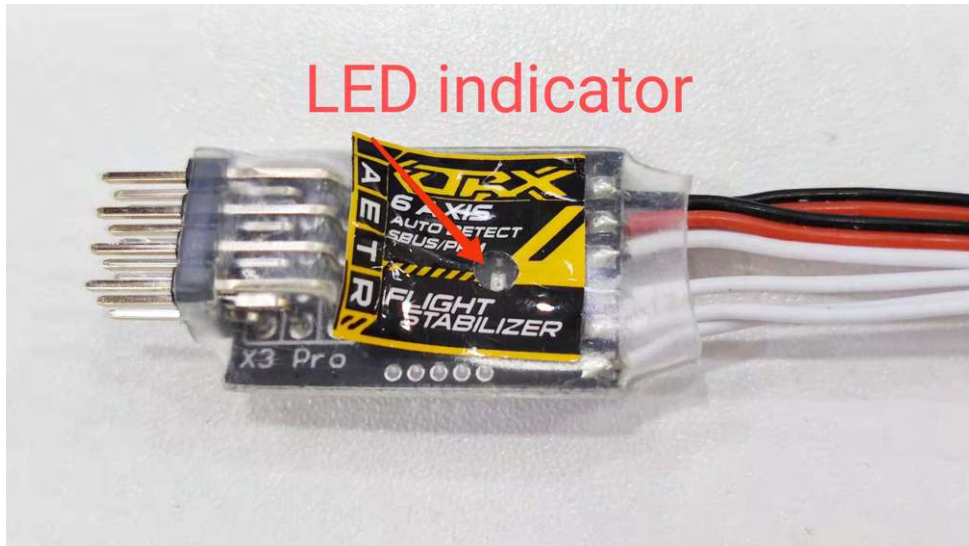

- LED light off (No radio signal)
- LED light turns solid (Beginner mode)
- LED light flashes quickly (Intermediate mode)
- LED light flashes slowly (Expert mode)

To arm the stabilization system you need to open the throttle to a low setting for 1 or 2 seconds then close the throttle. Now pick the model up and check to see if it is in beginners mode or advanced mode. To do this move the nose up and down and watch the elevator servo movement. If it's in beginners mode the servo will move quite a bit, in advanced mode the servo will move less. Set the stabilization system into beginners mode then check that it is working correctly by doing the following test. Roll the aircraft to the right, the left aileron should go up, and the right down. Roll the aircraft to the left, and the right aileron should go up, and the left down. Move the nose down, and the elevator should go up, move the nose up, and the elevator should go down. If all works correctly then you are ready to fly.







RC CONTROL

Roll Left: Move the aileron stick to the left, the left aileron should go up.

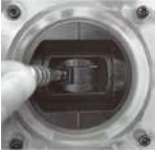
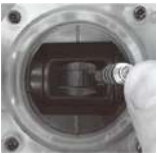
Roll Right: Move the aileron stick to the right, the right aileron should go up.

Pitch Up: Move the elevator stick down, the elevator should go up.

Pitch Down: Move the elevator stick up, the elevator should go down.

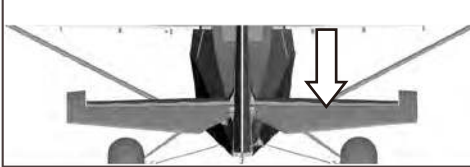
 	<p>Roll left</p> <p>Roll right</p>	 	<p>Aileron (Roll)</p>
 	<p>Pitch up</p> <p>Pitch down</p>	 	<p>Elevator (Pitch)</p>

GYRO CONTROL

1. You now need to check that the gyro is functioning correctly.
2. Move the gyro switch down into the "Training Mode", this is the switch in the fully down position. Now smartly roll the wings left and right, you should then see the ailerons moving in the opposite direction to the rolling moment. Then smartly pitch the nose of the plane up and down, you should then see the elevator servo moving the elevator in the opposite direction of the pitching. If you find it difficult to see which way a surface is moving, gently hold the surface, then as you move the model, you should be able to feel the servo moving in the opposite direction. When the gyro is in "Training Mode" this limits the amount of roll, and pitch, you can subject the model to. You can put a full control command in, and the model will only respond up to a certain angle. Also this mode will self right the model if it starts to spiral out of control. Just let go of the sticks, close the throttle, and the gyro will do the rest.
3. With the switch is in the middle position, "Gyro On" , perform the same actions as above, the servos will still move but to a lesser degree. In this mode the gyro will still be assisting your flying and helping smooth things out, but it does not limit the roll, and pitch, angles, nor will it self right as quickly. In this mode you will be able to perform simple aerobatics when you are ready.
4. Now put the switch into the "Gyro Off" position, now when you perform this test, the servos should not move at all. So in this mode you will get no gyro assist at all, this mode is only for experienced fliers.
5. Once these checks are complete, leave the transmitter switched on and disconnect the flight battery. Once the battery has been disconnected you can then turn off the transmitter. Never have the flight battery plugged in and the transmitter switched off, this is dangerous.
6. So a quick recap on the switching on, switching off process. Always switch the transmitter on first and check that the switches, trims and throttle stick are in their correct positions, only then plug in the flight battery. Once you have finished testing or flying, disconnect the flight battery first, and only then switch off the transmitter.

TROUBLE SHOOTING

Problem	Cause	Solution
Motor does not run	<ol style="list-style-type: none"> 1. Batteries are not fully charged. 2. Transmitter battery low. 3. Motor not connected. 4. The motor is damaged. 5. Receiver is not bound to Tx. 6. ESC in set-up mode. 	<ol style="list-style-type: none"> 1. Charge the batteries. 2. Install a charged battery. 3. Check the connection between the ESC and motor. 4. Replace motor. 5. Consult radio manual and go through bind procedure again. 6. Hold model and move throttle to full position then back down to idle.
<u>Model moves backwards</u>	<ol style="list-style-type: none"> 1. Fan is running backwards. 	<ol style="list-style-type: none"> 1. Swap any 2 motor wires over that go to the ESC.
<u>Control surfaces not moving with stick input</u>	<ol style="list-style-type: none"> 1. The servo lead is connected to Rx incorrectly. 2. The servo is damaged. 	<ol style="list-style-type: none"> 1. Make sure the servo leads are connected properly. 2. Replace servo.
<u>Model does not fly straight</u>	<ol style="list-style-type: none"> 1. Control surfaces are not centered. 2. C of G is not in the correct position. 	<ol style="list-style-type: none"> 1. Adjust the trims on the transmitter. 2. Re-position LiPo as suggested.
<u>Model does not climb well</u>	<ol style="list-style-type: none"> 1. The battery is not fully charged. 2. Elevator servo is reversed. 3. C of G too far backwards. 	<ol style="list-style-type: none"> 1. Charge the battery. 2. Change servo direction via Tx. 3. Move the battery backwards
<u>Limited radio range</u>	<ol style="list-style-type: none"> 1. Transmitter/Receiver batteries are flat. 	<ol style="list-style-type: none"> 1. Charge/replace batteries.

RECOMMEND BATTERY PACK



Turnigy Nano-Tech Plus 1000 mAh
4S 70C Lipo Pack w/XT60
SKU:9210000262-0



Turnigy Graphene Panther 1000 mAh
4S 75C Battery Pack
SKU:9067000360-0



Turnigy nano-tech 1000 mAh 4S
45~90C Lipo Pack
SKU:N1000.4S.45



Turnigy 1300 mAh 4S 60C Lipo
Pack w/XT60
SKU:9067000520-0

REPLACEMENT SPARE PARTS

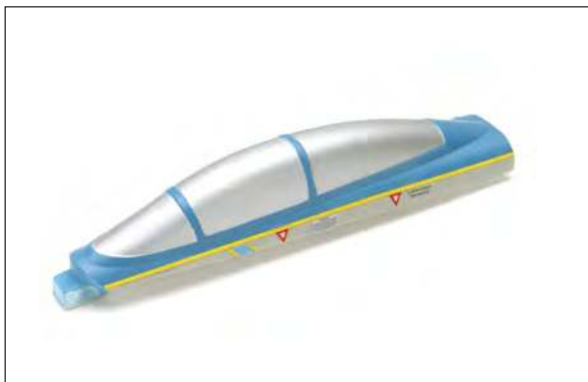

Canopy/Battery Hatch
SKU: 9306000580-0



Horizontal Stabilizer Set
SKU: 9306000581-0



Vertical Stabilizer Set
SKU: 9306000582-0

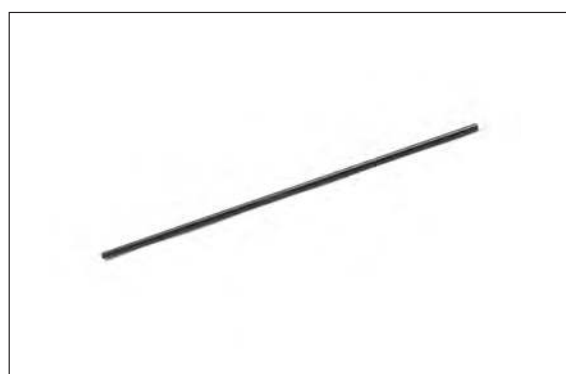

Carbon Wing Spar
SKU: 9306000583-0



Pushrod Set
SKU: 9306000584-0



50mm EDF Fan/Motor Set
SKU: 9306000585-0

H·KING



APEX CE SPECIALISTS LIMITED

89 Princess Street, Manchester,
M1 4HT, UK



APEX CE SPECIALISTS LIMITED

Unit 3D North Point House,
North Point Business Park,
New Mallow Road, Cork, T23 AT2P, Ireland



Made in China